

**Customer**

## Technical data

### Glanded standard pump Atmos GIGA-N 125/200-15/4

Project name: Untitled project 2023-04-17 06:56:01.101

Project ID  
Installation location  
Customer pos. No.

Date: 17.04.2023

#### Duty chart

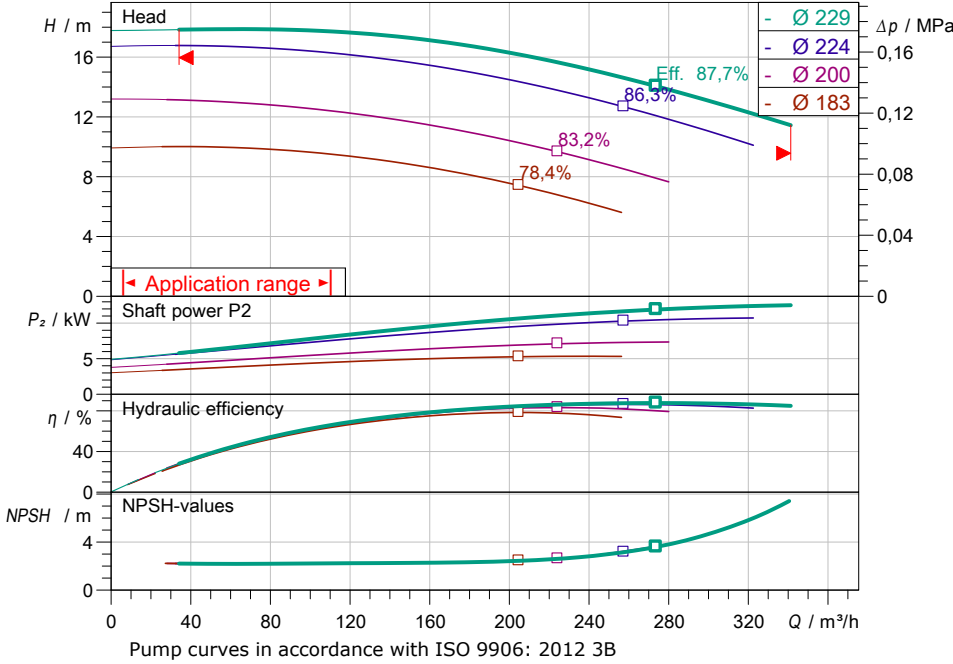

#### Requested data

Flow  
Head  
Media: Water 100 %  
Fluid temperature: 20,00 °C  
Density: 998,30 kg/m<sup>3</sup>  
Kin. viscosity: 1,00 mm<sup>2</sup>/s

#### Hydraulic data (Duty point)

Flow  
Head  
Shaft power P2  
Hydraulic efficiency  
NPSH  
Impeller size: 229

#### Product data

Glanded standard pump  
Atmos GIGA-N 125/200-15/4  
Max. operating pressure: 1,6 MPa  
Fluid temperature: -20 °C ... +140 °C  
Max. ambient temperature: 40 °C  
Minimum efficiency index (MEI): ≥ 0.4

#### Motordata per Motor/Pump

Motor efficiency level: IE3  
Mains connection: 3~ 400 V / 50 Hz  
Permitted voltage tolerance: +-10 %  
Max. speed: 1465 1/min  
Rated power P2: 15,00 kW  
Rated current: 27,90 A  
Power factor: 0,78  
Efficiency: 50% / 75% / 100% → 92,2/92,5/92,3%  
Degree of protection: IP55  
Insulation class: F  
Motor protection: PTC integrated

#### Fitting dimensions

Pipe connection on the suction side: DN 150, PN 16  
Pipe connection (pressure side): DN 125, PN 16  
Port to Port

#### Materials

Pump housing: 5.1301/EN-GJL-250  
Impeller: EN-GJL-200  
Lantern: 5.1301/EN-GJL-250  
Shaft: 1.4021  
Shaft seal: AQ1EGG

#### Information for order placements

Weight approx.: 416 kg  
Item number: 6086236

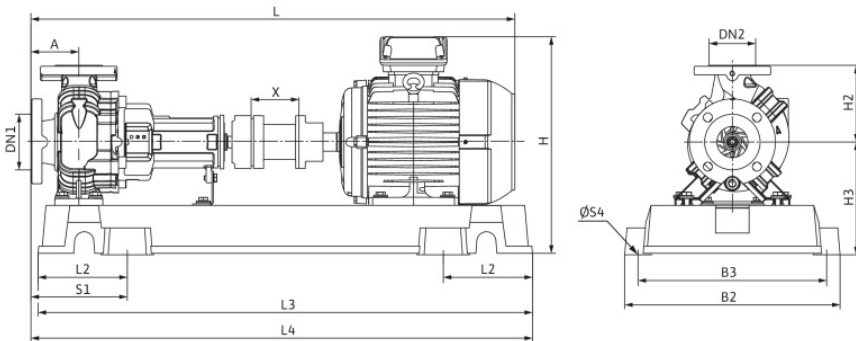

#### Dimensions

mm

DN1	DN 150, PN16	617	L3	1440
DN2	DN 125, PN16	315	L4	1470
A	140	H3	S1	280
B2	610	L	S4	29
B3	550	L2	X	140

# Hydraulic data

Glanded standard pump  
Atmos GIGA-N 125/200-15/4

Project name: Untitled project 2023-04-17 06:56:01.101

Project ID  
Installation location  
Customer pos. No.

Date: 17.04.2023

## Operating data

Speed <b>1467 1/min</b>	Frequency <b>50 Hz</b>	Duty point <b>Q =</b>	<b>H =</b>	Suction port <b>DN 150</b>	Discharge port <b>DN 125</b>
----------------------------	---------------------------	--------------------------	------------	-------------------------------	---------------------------------

Power data referred to: Water; 20°C; 998,3kg/m³; 1,005mm²/s ±10% tolerance with linear U/f frequency control

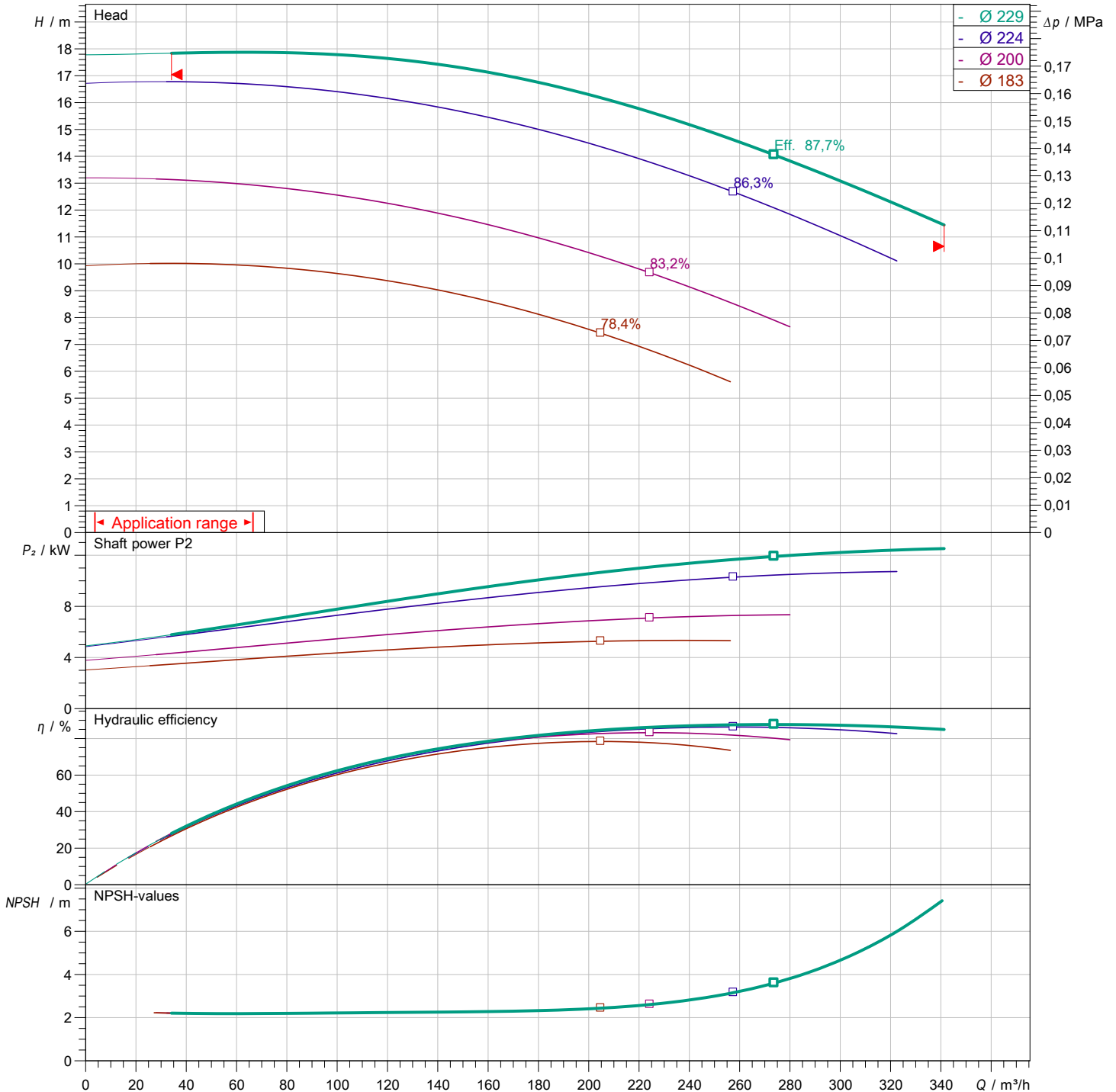

Contact  
E-mail  
Phone

**Customer**

Contact  
E-mail  
Phone

## Dimensions

Glanded standard pump  
Atmos GIGA-N 125/200-15/4

Project name                      Untitled project 2023-04-17 06:56:01.101

Project ID  
Installation location  
Customer pos. No.

Date                      17.04.2023

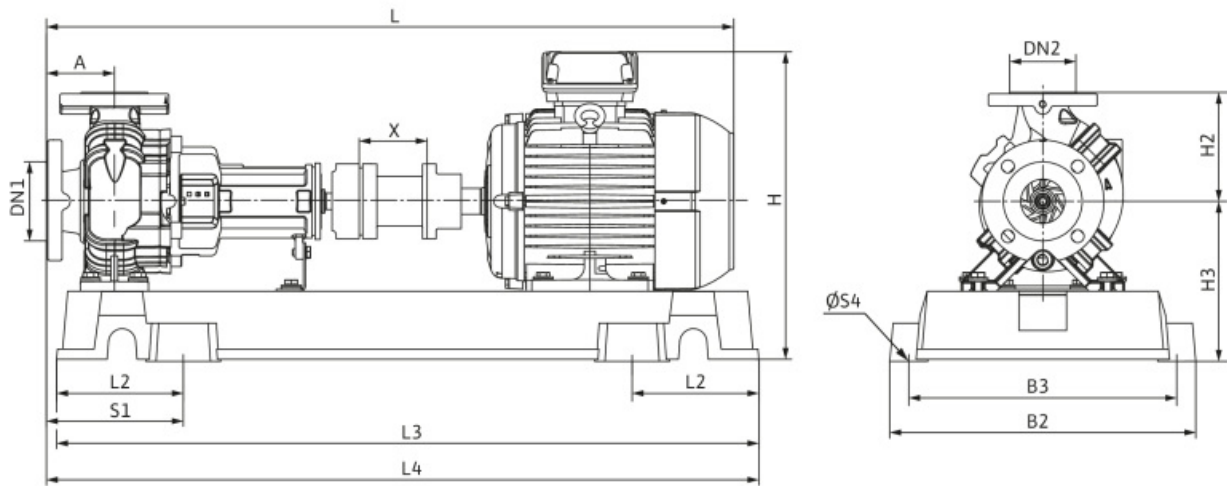

Coupling with spacer

Suction side                      DN 150, PN 16  
Discharge side                      DN 125, PN 16

**Dimensions**                      mm

Name	Value	Name	Value	Name	Value	Name	Value
DN1	DN 150, PN 16	H3	353	X	140		
DN2	DN 125, PN 16	L	1392				
A	140	L2	250				
B2	610	L3	1440				
B3	550	L4	1470				
H	617	S1	280				
H2	315	S4	29				