

BIO-CEL[®] Submerged MBR Solutions



Submerged MBR Modules for Biological Wastewater Treatment

It is becoming increasingly challenging for conventional wastewater treatment plants to keep up with tighter discharge regulations, urbanization, and increased demand for water recycling.

BIO-CEL® MBR is a cost-effective and scalable solution for meeting challenging effluent requirements for municipal and industrial wastewater treatment.

HIGH EFFLUENT QUALITY - TWO TIMES SMALLER FOOTPRINT

BIO-CEL MBR creates a cleaner, higher quality effluent than conventional wastewater treatment systems, using up to two times smaller overall footprint due to its high packing density.

The BIO-CEL ultrafiltration membrane serves as an effective physical barrier for the retention of solids and bacteria. The modules produce a high volume of superior quality effluent at a consistent flow rate. This is especially useful for water reuse applications.

SMART MODULE DESIGN - 360° ACCESS

BIO-CEL MBR modules were the first flat-sheet membrane-based MBR modules with 360° access. The open design minimizes dead zones where braiding and sludge accumulate.

FIVE TIMES LESS CLEANING - REDUCED CHEMICAL USAGE

The membrane stack can be accessed easily for cleaning and maintenance, facilitating a more thorough cleaning process and extending cleaning intervals. Modules can be cleaned in-situ and do not require a separate cleaning tank. The BIO-CEL MBR membrane laminate combines the advantages of flat sheet and hollow fiber membranes, allowing backwash and increased durability.

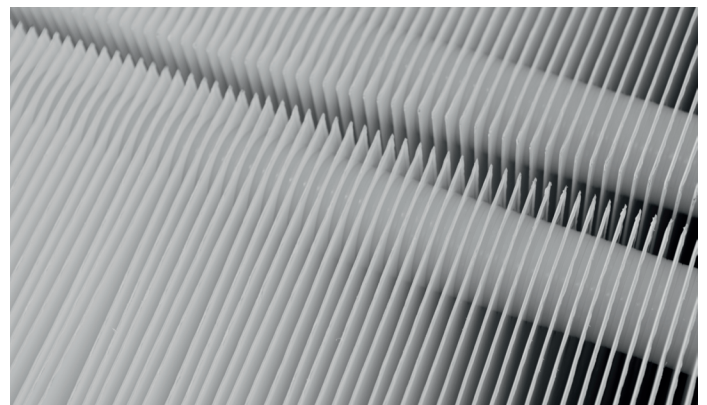

SELF-HEALING MEMBRANE LAMINATE

BIO-CEL MBR modules were the first modules to use membrane laminate technology and the first to benefit from its self-healing effect.

FINE BUBBLE AERATION

The special diffusers create fine air bubbles that help save energy and generate a consistent crossflow between the membrane laminate sheets. The oxygen transfer is more efficient with fine than coarse bubble aeration systems.

Remote Online Monitoring with Streametric!

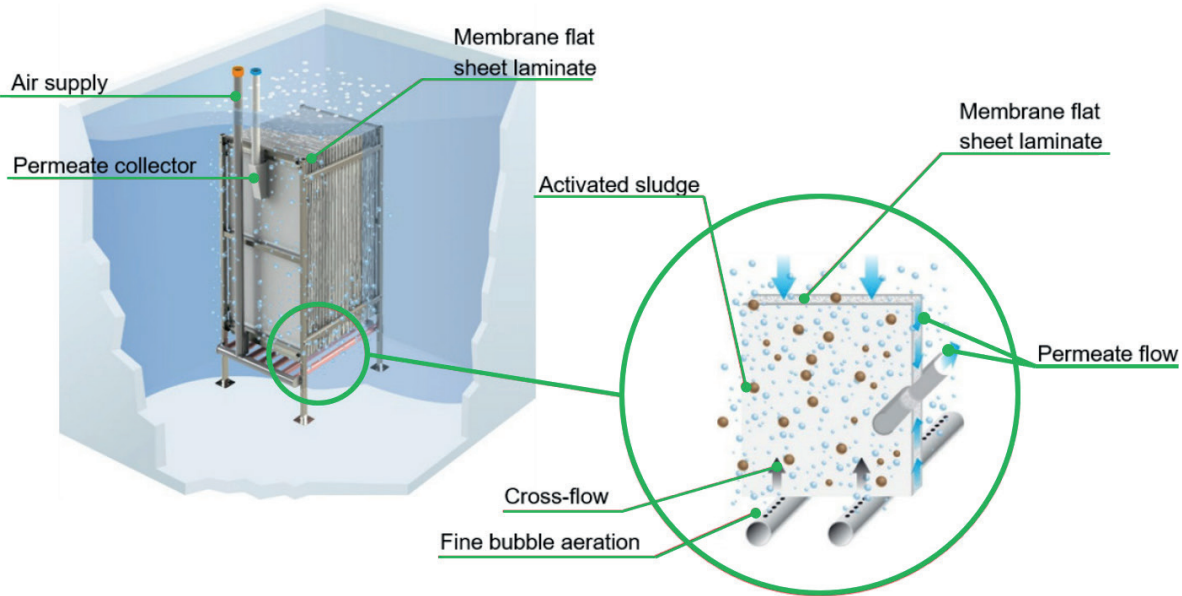

OPERATION OF BIO-CEL® MBR MODULES

In a membrane bio-reactor (MBR) system, the biomass treats polluted water, while the membrane ensures the safe separation of the biomass from the cleaned wastewater. Traditionally, this separation process relied on solids settling in a secondary clarifier. In addition to better effluent quality, MBRs have the advantage to be operated with much higher MLSS (Mixed Liquor Suspended Solids) levels. Thus, an MBR plant requires less space than a conventional plant.

The key elements of an MBR system are the membrane and the aeration. The membrane serves as a physical barrier for the retention of solids and bacteria. The aeration generates the crossflow, which transports the mixed liquor along the membrane surface. This crossflow prevents the accumulation of sludge on the membrane surface, resulting in a consistent and reliable operation.

The treated water is collected in a permeate channel and can be safely discharged. The permeate from BIO-CEL® MBR modules may be fed directly to a reverse osmosis (RO) process. MICRODYN RO membranes are suitable for this application.

MEMBRANE FLAT SHEET LAMINATE WITH SELF-HEALING EFFECT

The integrity of the membrane plays a significant role in MBR wastewater treatment. BIO-CEL MBR membrane is laminated on both sides onto a special spacer material, then the laminate sheets are cut and welded on the sides. The result is a 2 mm thick laminate suitable for the MBR application. In the event that the membrane is damaged, the spacer material seals off the damage using the biomass in the system. Solids and bacteria can still be rejected by the membrane laminate. Laboratory tests have shown that the membrane laminate “heals” itself in less than two minutes, even under the most adverse conditions.

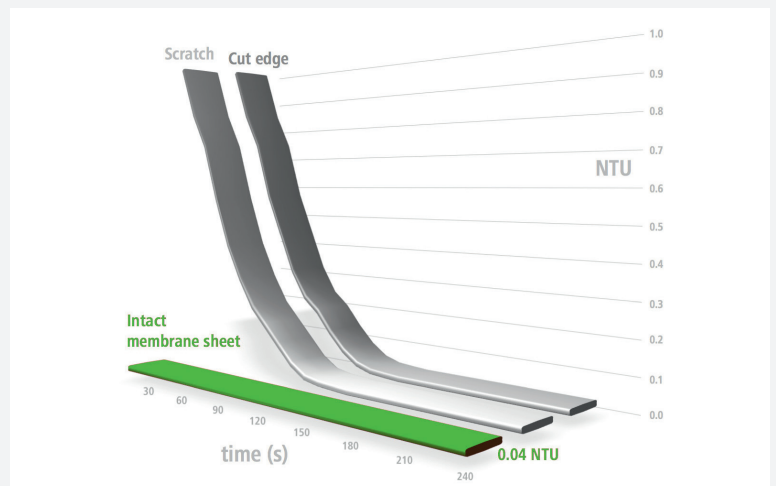

BIO-CEL[®] MBR Module Configurations

MEMBRANE MATERIAL

- **Polymer:** PES
- **MembraneType:** Ultrafiltration
- **Support Layer:** Polyester
- **Drainage:** Polyester

MODULE CONFIGURATIONS

BIO-CEL[®] MBR modules consist of one or more membrane cassettes. With this modular configuration, BIO-CEL MBR is a scalable solution for both small and large wastewater treatment plants.

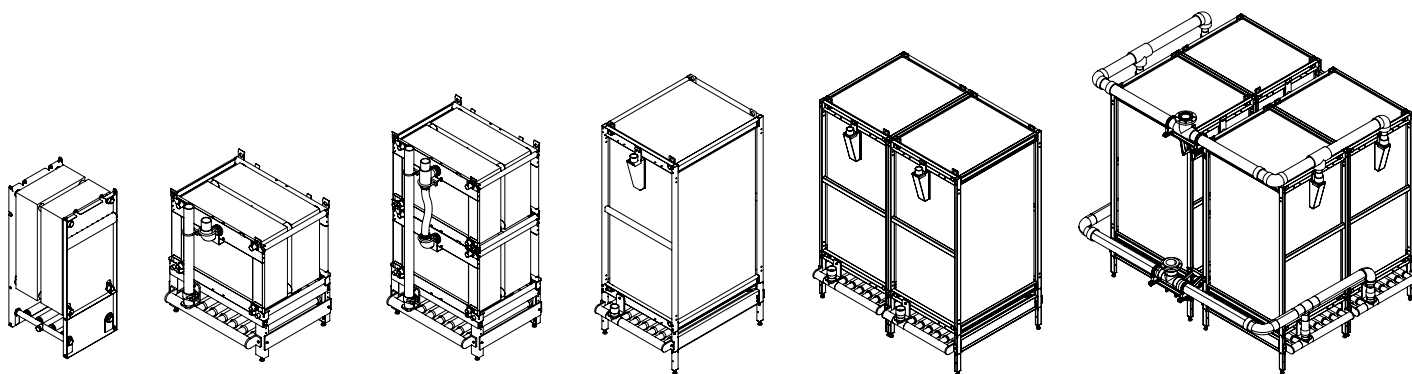

AVAILABLE MODULE TYPES

Module Type	Membrane Material	Membrane Area [m ²]	Membrane Area [ft ²]	No. of Cassettes	Dimensions [mm]	Dimensions [ft]	Housing Material
EASY	PES	50	108	1	280 x 747 x 1515	0.9 x 2.5 x 5	Stainless Steel
M+100	PVDF	100	1076	1	1213 x 1072 x 1345	3.98 x 3.5 x 4.5	Stainless Steel
M+200	PVDF	200	2152	2	1213 x 1072 x 2340	3.98 x 3.5 x 7	Stainless Steel
L-2	PES	480	5167	1	1524 x 1080 x 2435	5 x 3.5 x 8	Stainless Steel
L-2 Double	PES	960	10333	2	1524 x 2160 x 2435	5 x 7 x 8	Stainless Steel
XL-2	PES	1920	20667	4	3200 x 2750 x 2750	10.5 x 9 x 9	Stainless Steel

Note: nominal values

Europe

Germany: +49 611 962 6001
Italy: +39 0721 1796201
info.wfs@mann-hummel.com

Americas

USA: +1 805 964 8003
sales.mnus@microdyn-nadir.com

Asia

APAC: +65 6457 7533
China: +86 10 8413 9860
waterchina@mann-hummel.com

www.mann-hummel.com

MANN+
HUMMEL