

Simplicity is the ultimate sophistication.

Leonardo da Vinci

MASTER OF REVOLUTION



PlanetDISK[®]

Biological Waste Water Treatment Systems. Rotating Biological Contactor (RBC)

Presenting the World's most economical, reliable and sustainable domestic decentralized waste water treatment solution.



We are one of the most important companies for the **World**.

Letter of the Founder



The most serious problem of our Planet in the 21st century is the rapidly depleting natural resources and scarcity of clean water.

In 2004, when I started PlanetTEK, my sole purpose was to serve the world and help to save the rapidly disappearing natural resources and make an impact for the better.

In order to protect the water sources and be able to reuse the treated wastewater, I wanted to locally manufacture a compact biological treatment unit utilizing a technology which was favored in Europe, USA and Canada. Biodisk technology was using less energy, had smaller footprint, easy-maintenance and was able to serve trouble-free for many years if engineered correctly with the right choice of materials.

This is how PlanetDISK® is born! (You may watch my personal and PlanetDISK's story "The World Needs "Heroes"" at TEDx Conference by searching key words of "TEDx Aydoğan" at YouTube)

I named our company PlanetTEK, TEK meaning the "only one" in Turkish, and short for technology in English. The One and Only Planet's clean water sources are depleting so fast, soon, water would be the most expensive element on the face of the Planet!

When I was born in 1960, world's population was under 4 billion. Today it is 7 billion and expected to exceed 9 billion by the year 2050! The overall GNP in 1950 was € 4 trillion where today, it is over € 50 trillion.

Price the world has to pay for such increase is enormous. In the end we might inherit our children and grandchildren the perfect technological products such as smartphones and cars that do not require drivers, But would they really thank us for having all of these in a world without clean water resource or clean air to breathe?

After 14 years of many successful implementations, PlanetDISK® has become the RBC brand name of reliable, solid state of biological waste water treatment and recycling systems for capacities between 200 - 20.000 people.

For a Planet we can live in, sustainable waste water treatment technologies are needed. Success of treatment systems depends on ease of maintenance and low energy cost. Thanks to PlanetDISK®, since 2004, this is exactly what we have been achieving as PlanetTEK!

We are proud of how far we have come and continuously working harder to move further! We thank all the customers who gave us the valuable opportunity to serve the Planet with their trust in our products and service.

Hürriyet Necdet Aydoğan

Founder - CEO,
Bs Mechanical Eng. and Ms Industrial Eng.

PlanetDISK® RBC Technology

Among all known domestic wastewater treatment technologies the one that requires the least amount of energy and less maintenance.



Sustainable, consistent and dependable process results. Since 2004

Why PlanetDISK® RBC Units?

Technology Inspired by Nature

What makes PlanetDISK® so perfect is the sheer simplicity behind its design and principle of how it works. This brings along simplicity in operation and maintenance.



Low Energy Demand

RBC System saves up to 90% in energy costs. Among all known wastewater treatment technologies, RBC is the one that consumes the least amount of energy. Typical blower for an activated treatment plant with a capacity of 250-350 pe requires 4-5.5 kW. For a similar capacity plant, PlanetDISK® uses a 0.37kW electrical motor and a reduction gear to rotate the rotor at 3-5 rpm. That is all the energy required in the reactor part! Monthly energy costs per person per month at a typical PlanetDISK® plant is less than \$0.1.

Renewable Energy Resources

Due to system's low energy demand, it is easily operable with either solar or wind power.

No Smell No Noise

No annoying smell or noise. The rotor rotates at 3-5 rpm and requires merely 0.37 kW. It is quiet! Each time the rotor surface is exposed to the atmosphere, plenty of oxygen diffuses to all the bacteria in the biofilm. There is no blower to blow the smell out of the system. One can place PlanetDISK® unit nearby a swimming pool.

Dependable Under Variable Loads

Consistent process results even the organic load may vary up or down by 250%. Since the microorganisms in a fixed film system are attached to a media, they cannot wash out with increased flows or loads. In villages or gray water projects, even though the bacteria levels are low and the waste water is diluted, the system still performs well and delivers required standards.

European Standards

Nitrification, denitrification and phosphor removal are all successfully achieved by RBC systems. When the effluent BOD level is below 15 ppm, nitrification is achieved. When the water is fed back to one of presedimentation tanks acting as anaerobic tank, partial denitrification occurs. Phosphor removal is achieved by flocculation or filtration. Effluent values of 10-15 ppm BOD can easily be achieved by PlanetDISK® RBC systems.

Reuse of Waste Water

With tertiary treatment (sand+activated carbon filter) and disinfection (UV or chlorine) treated waste water can be used for irrigation, car wash, toilet flushing, cooling tower water and also at construction sites.

Easy Maintenance

Simple and economical to run. Does not require constant maintenance as required in activated sludge system

Long Lasting

All the materials used in manufacturing PlanetDISK® units are corrosion proof. HDPP disks, HDPE or GRP body tank, rotor which is in contact with water is SS and/or galvanized metal. Solid shaft is chrome plated and/or epoxy paint protected. It is designed and built to serve many years. Heavy duty bearings are pillow block type with self-aligning spherical roller bearings. Disks are made of 1 piece all new virgin material.

Excerpt from a technical article published in the USA:

Reconsidering Rotating Biological Contactors

"A brief overview of what we found was that RBCs may be the best process choice for some wastewater treatment plants because of their proven simplicity, reliable performance, and low energy usage.

Why RBC is preferred in most cases?

"VRI Environmental Services, Inc. currently operates over 80 water and wastewater treatment facilities in the United States. ... In my experience RBC's provide a very economical and robust solution to wastewater treatment. ... The RBC is very easy to operate."

Principal/President, VRI Environmental Services, Inc., Millbrook, New York



PlanetDISK® plant for 2000 pe at service of small community, Igneada Village, Blacksea region of Türkiye.



The first PlanetDISK® unit at service since 2005. Still rotating and treating perfectly!

"Our RBC system, with 10 shafts, has been running for over 20 years and has proven to be a good, simple, low energy usage system,

requiring low operational attention. It has reliably met our effluent limits." **Superintendent, Grosse Ile Wastewater Treatment Plant, Grosse Ile Township, Michigan.**

"Our first RBC's were commissioned in 1980. It's a great process. They flat-out work. There is not a lot of operator intervention required. The RBC's are energy efficient and easy to maintain. Our plant is located in the downtown area and we have not had any complaints about plant odor in all that time. I would highly recommend the use of RBC technology for municipal wastewater treatment." **Director of Wastewater Operations, Holly, Michigan"**

What makes PlanetDISK® RBC the better choice among all the wastewater treatment technologies?

1- PlanetDISK® RBC Unit is a fixed film reactor system consisting of circular disks made of non-corrosive, all new virgin material. High Density PolyPropylene (HDPP), mounted on a solid chrome coated steel shaft rotating at speeds of 3-5 rpm.

2- The entry part of the RBC system must have screens and also grease trap. FOG (fat, oil, grease) especially must be kept out in RBC systems. Since the bacteria forms a biofilm on the surface of the disks, only the soluble BOD must be allowed into the RBC reactor. That means that the settleable BOD must be held in sedimentation tanks. Mechanical ways of screening will not replace sedimentation which also reduces the BOD load by approximately. 30%.

3- During the rotation, 40% of the disks are immersed in wastewater. The rotation of the rotor exposes biomass on disks to oxygen, allowing organisms to multiply. The dissolved oxygen and organic materials in wastewater diffuse into the biomass to be metabolized.

4- This is all a natural process performed by the microorganisms in the waste water. Bacteria act as cleaners themselves. The organic load in waste water is bacteria's "food" and the bacteria "eat and digest" each other. The operator does not have to interfere to clean the disks. Biomass thickness may vary between 1-2.5 mm and excess biomass shears off at a steady rate by gravity as the disks turn. The disks are separated from each other by plastic rings of 14-17 mm thickness.

5- The converted suspensors are removed sludge (Total Suspended Solid) and is collected at the final clarifier such as lamella clarifiers (built by PlanetTEK) at final sedimentation stage. Filtration can also be utilized for such purpose. After tertiary treatment via filtration and disinfection (UV, Chlorine, etc) the water can be reused.

Flow Diagram of PlanetDISK® Rotating Biological Contactor Wastewater Treatment Plant

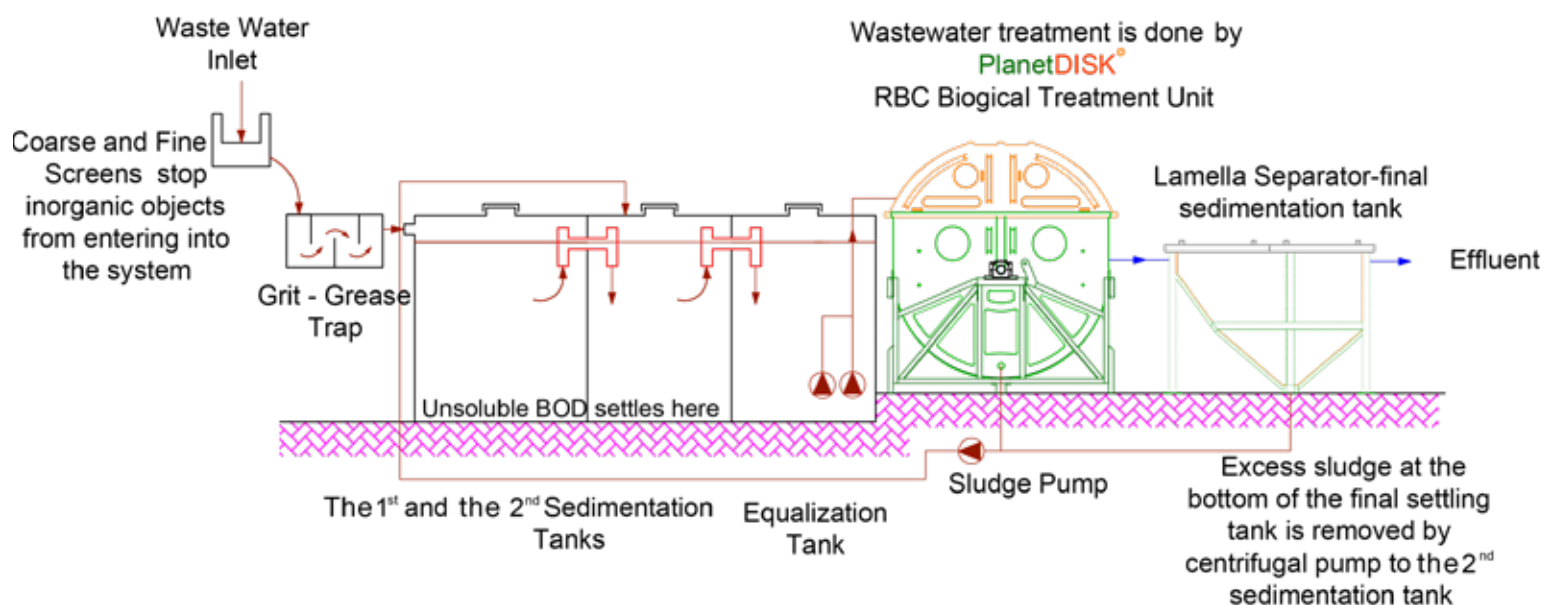

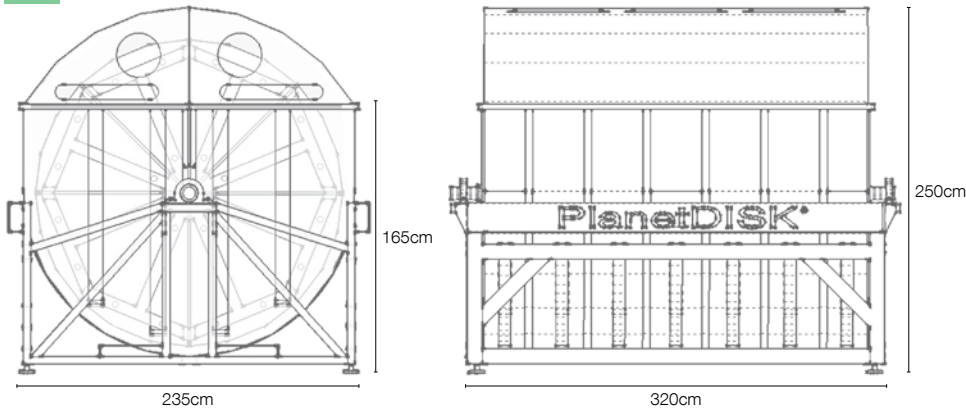

Technical Data PlanetDISK® MX1 Model

Treatment Plant Capacity: 10 – 4000m³/day

Each unit capacity = 40-70 m³/day depending on BOD load and effluent and influent characteristics

Each unit power requirement= 0.37 – 0.55 kW

NON-CORROSIVE MATERIALS

- Polyethylene or GRP holding tank
- HDPP (High Density Polypropylene) virgin material Discs
1.7mm thickness. 2050 mm dia. Each disc is 1 piece.
- Heavy duty bearings are pillow block type with self-aligning spherical roller bearings.
- Epoxy painted or chrome plated AISI 1050 – C50 Carbon Steel, 85 mm diameter Solid Shaft
Galvanized steel SS or Galvanized Steel structure cage.
- Epoxy painted chassis.

DELIVERY & PACKING

- Unit dimensions= 2350mm x 3200mm x 2500mm(h)
- Empty weight ≈ 1900kg.
- Full operational weight≈7500-8000kg.
- 3MX1 units to fit in 40ft HC shipping containers
- Manufactured in Türkiye

PlanetTEK Inc. continuously develops products and has the right to make changes in technical specs of her products without prior notice.

With proper care and maintenance, life expectancy of PlanetDISK® units is a minimum of 20 years.

Should the bearings or the reduction gear needs to be replaced, it takes any skilled labour under an hour to do the work. All parts are readily and world- wide available. Discs are made of virgin HDPP material. Holding tank is GRP – fiber glass. Both materials will last over 100 years.

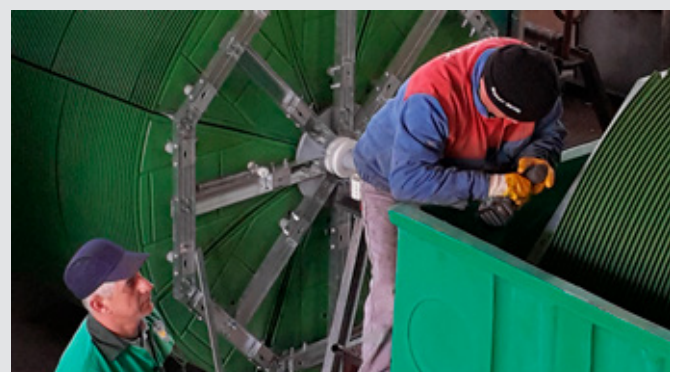
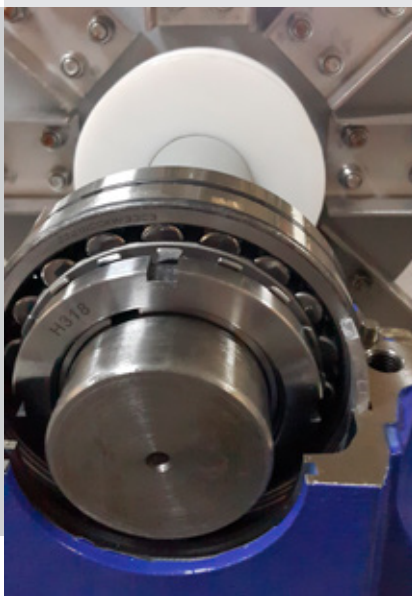

PlanetDISK® Rotating Biological Contactor Domestic Wastewater Treatment Plant Capacity of 140m³/day 500 p.e. (Winter) - 600 p.e. (Summer)

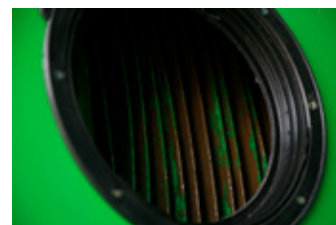
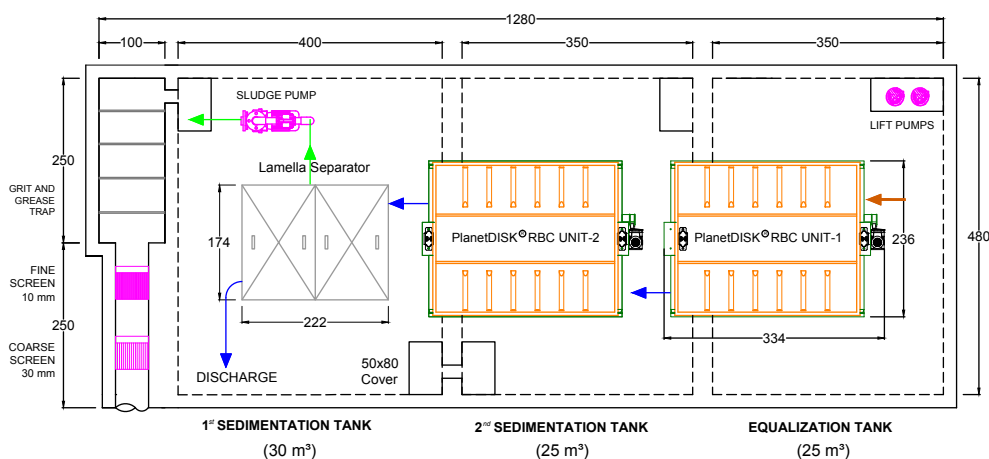
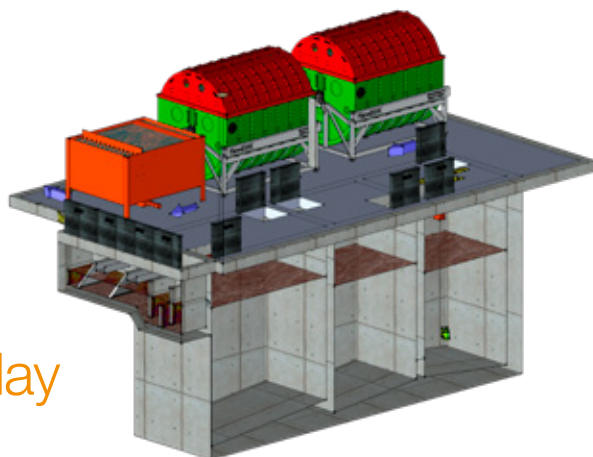

This is biofilm attached to the surface of the HDPP disks. Rotation of the rotor exposes biomass to oxygen.

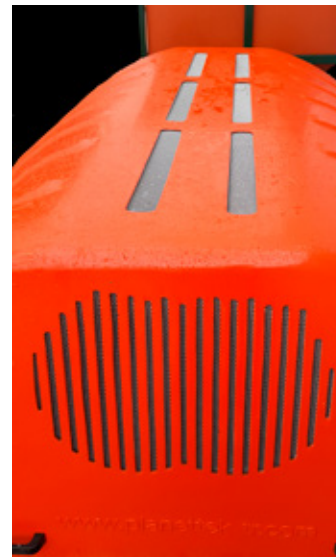
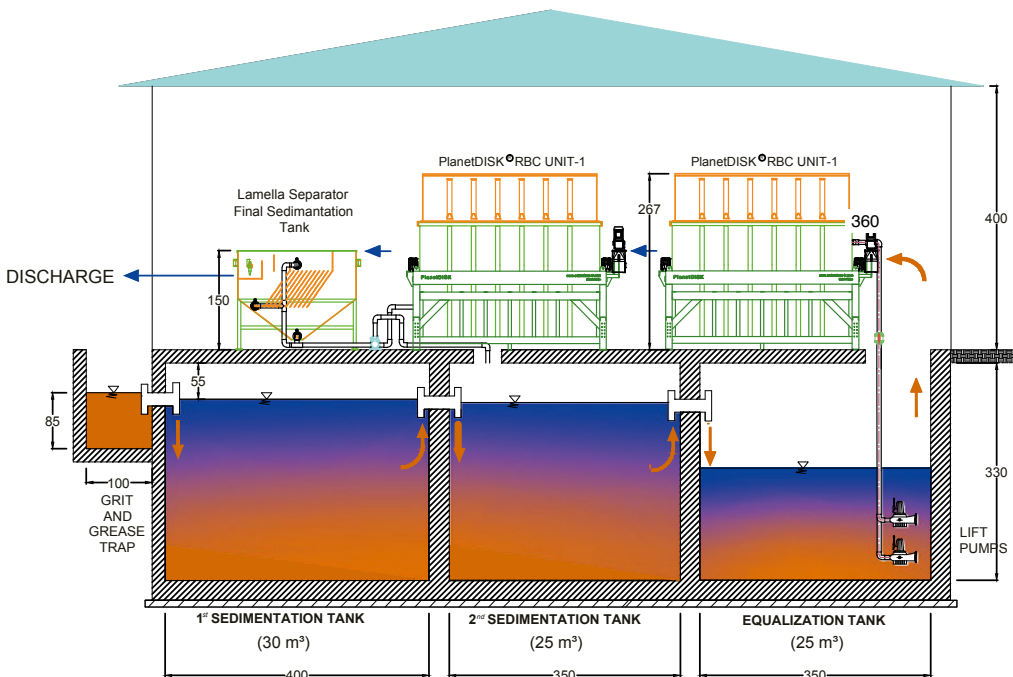

Oxygen reaches the bacteria on the disks thru several windows placed on the cover of PlanetDISK® unit. Cover of the unit is optional. The unit can be used without it.

Drawing not to scale.

Influent Parameters
 BOD = 300 mg/L
 Organic Load = 60 g/pe-day
 Hydraulic Load = 230 L/pe-day

Effluent Parameters
 BOI < 25 mg/L

Required Area
 50-60 m²



Case Studies



PlanetDISK® MX1 Model RBC Units are at work in small town Balya of Balikesir Province, at Aegean shore. Capacity of this particular plant is 3500 people – 350m³/day. Capacities of PlanetDISK® RBC units and therefore the total number of RBC units at a plant may vary depending on the influent waste water and effluent criteria of the treated water.

Main concern was to save energy and maintenance cost. RBC – Rotating Biological Contactor Technology is the least energy consuming biological waste water treatment way among all known methods and technologies. It can easily be operated by solar and other renewable energy sources.

Balikesir Province Water and Sewage Authority (BASKI) switched to PlanetDISK® after trying other methods including MBR and SBR and electrocoagulation.





At PlanetTEK, you're more than just a client – we see you as our partner in protecting our most precious natural resource, water. By choosing PlanetDISK®, one of the most effective, reliable and sustainable biological waste water treatment systems in the industry, you're helping to preserve our natural resources for future generations. We deeply respect every organization who joins us in our mission and are committed to providing the highest level of service to you, our valued partner. Together, we will make a difference!

Hürriyet Necdet Aydoğan
Founder and CEO - PlanetTEK Inc.



*Sewage Treatment Plant with
90% Energy Saving
Easy maintenance
Consistent Process Results.*



Prestigious Bosphorus University used conventional systems to treat Waste water for many years.



Thanks to PlanetDISK® RBC Systems, Bosphorus University Campus don't have any noise or smell problems any more. They are saving over USD 20,000 per year in energy bills and they can use part of the treated water for irrigation at the campus. This was news covered by CNN Turk!

Why did Bosphorus University switched to PlanetDISK® RBC Systems for 3500 people/day capacity waste water treatment?

Case Studies

Why there is PlanetDISK® RBC System in Mardin village of Surgucu, population 4500 people?



Mardin is a historical city in the Southeast part of Türkiye. Cities in this area has chronic shortage of water. One of the most effective ways to protect the clean water sources is to treat the wastewater before discharging it to the nature. Mardin Greater City Water and Sewage Authorities (MARSU) searched for a sustainable way to treat the waste water of small settlements between 1000-7500 people capacity. PlanetDISK® system is operated by solar energy, requires limited amount of maintenance by non-skilled labor. Due to these reasons PlanetDISK® was preferred as the correct method to treat wastewater of small settlements in Mardin.

Solar powered STP with a capacity of 4500 people – 650m³/day



Why did the German Finance and Development Bank of KfW made the RBC a must for the small settlement waste water treatment projects in Batum city of Georgia? Why is PlanetDISK® preferred among all the international brands as the winner?

Building decentralized small capacity wastewater treatment systems is a challenge in many ways. Greater capacity municipal wastewater treatment systems has many technical staff to run and maintain the system. In smaller systems, there is no trained or skilled people to operate the system. KfW has chosen RBC technology as the most energy saving and easy maintenance technology wastewater treatment system for a sustainable treatment plant.

After studying several years of successful track record and international references of PlanetTEK, KfW has approved PlanetDISK® as the winning RBC company. PlanetDISK® also has the most value for the money with several features offered.



Case Studies



Why are international prestigious companies such as FRENCH VEOLIA, METITO OF QATAR, ARAMCO, TURK TEKFEN, CAPITAL WATER OF CHILE and many others are preferring PlanetDISK® project after project?

PlanetTEK Inc has proved its expertise in RBC Systems and projects for the last 14 years. Most of his customers are repeat customers. PlanetTEK's speciality area is RBC equipment only. PlanetTEK's Registered Trade Mark PlanetDISK® is one of the less than 20 registered RBC brands in the whole World. It is made in Türkiye according to EU standards and has CE certificate.

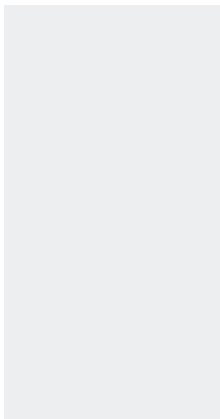

Name of Customer and the Project:

LIPTON TEA - UNILEVER - Türkiye

Sustainable waste water treatment solutions at tea harvesting villages at Black Sea Region of Türkiye.
Corporate's Social Responsibility Project.

Overall Picture

The village of Dikkaya of Rize Province is just another beautiful village at Black Sea region of Turkey. The village, like several other villages nearby is located by Firtına Vadisi – Storm Valley popular with rafting, hiking and other nature activities. Unfortunately the waste water from these villages run directly to small streams that eventually go into Storm River and to the Black Sea. LIPTON Tea teamed up with Istanbul Technical University (ITU) and suggested the Governor of Rize Province that they can sponsor a Waste Water Treatment Plant (WWTP) to serve one of the villages in the area.

Challenges and Solutions

There were several challenges to overcome in this village WWTP project:

1-Problem: The major concern of the Governor of Rize was the energy cost of the WWTP. The chosen system has to be energy efficient.
Solution: PlanetDISK® energy cost per person per month is less than \$0.1 per month! This is only a fraction of what the Governor was expecting to pay for the energy cost.

2-Problem: Maintenance has to be easy. There are no trained personnel in the area for small package type WWTP.

Solution: PlanetDISK® is already being used at villages of Ankara, Edirne, Samsun, Mardin and several other provinces. The amount of maintenance is less than 15 minutes per 2-3 days. And the personnel doesn't have to be qualified as a technician or an engineer. Unlike conventional methods, little operator intervention and monitoring will be sufficient. The results will not heavily depend upon human factor.

3-Problem: It rains a lot in the region and unfortunately the rain will mix up with the sewer entering the WWTP. The WWTP has to be able to handle both hydraulic and organic fluctuations.

Solution: Fixed film systems such as PlanetDISK® RBC generally have a greater mass of microorganisms, enabling to handle organic load increases. Besides, fixed film systems perform well even with diluted waste water. The activated sludge process, on the other hand, is more susceptible to performance deterioration due to hydraulic and organic load variations. Rapid flow increases tend to wash

microorganisms out of the aeration tank at precisely the time that a high concentration of microorganisms is needed.

4-Problem: The villagers have often heard that the WWTP have loud noises that will be disturbing and also causes bad smells in the area.

Solution: The Governor was very pleased when he saw the reference letters of other Governors regarding the lack of odour or noise. He also noticed that PlanetDISK® systems were quiet and odour free to place near by houses or by swimming pools at luxury housing sites.

5-Problem: The terrain is difficult and the whole area is covered by tea gardens. Land is very much limited. Villagers and the Governor want waste water treatment plant but not very much willing to give up the limited tea gardens they have!

Solution: PlanetDISK® RBC System footprint is 50% less than conventional systems.

There are close to 1000 treatment companies in Türkiye.

Facing such challenges, ITU and LIPTON decided to choose PlanetTEK as their partner in this very prestigious and challenging Project.

Conclusion and lessons taken:

PlanetDISK® Plant is commissioned in October of 2014. The analysis results always meet the standards and often were better than expected. Each case study has its own unique challenges and has to be handled individually. LIPTON Social Responsibility Project was no exception and there were problems that wasn't taken into account. We will openly share the most valuable experience we gained in this Project:

The villagers throw baby diapers and similar trash into the toilet. Unlike in other villages, we had pamphlets printed and distributed to the villagers advising not to use the toilets as trash cans. Such problem made it very difficult to maintain the coarse and the fine screens free of debris. Mechanical automatic screen is considered for the future projects.



Project Snapshot - LIPTON Project - Black Sea - Türkiye

PARAMETER	VALUE	UNIT
Population	400	person
Capacity (Hydraulic Load)	52	m ³ /day
Per Capita Flowrate	130	L/person.day
Per Capita Organic Loading	50	g/person.day
Total Organic Load	20	kg/day
Inlet Temperature	15-30	°C
Inlet BOD ₅	385	mg/L
Inlet COD	700	mg/L

Energy Cost Comparison of PlanetDISK® Unit vs Activated Sludge Units

	PlanetDISK Unit Reduction Gear	Activated Sludge Blower
Number of Unit	1	1
Power of motor (kW/hour)	0.37	5.5
Total Power (kW/hour)	0.37	5.5
Power Consumption Rate %	60	85
Power Consumption (kW)	0.22	4.67
Power Cost (USD/kW)	0.1	0.1
Daily Operating Time (hour/day)	24	24
Annual Power Cost (USD)	192	4.100
Annual Saving (USD)	3.908 USD	



Different Installation Methods



Containerized PlanetDISK® units are used at Jeddah - Yanbu pipeline project of ARAMCO of KSA.

Containers are transported to different locations as the construction site and the crew moves! PE tanks are used for sedimentation and equalization tanks.

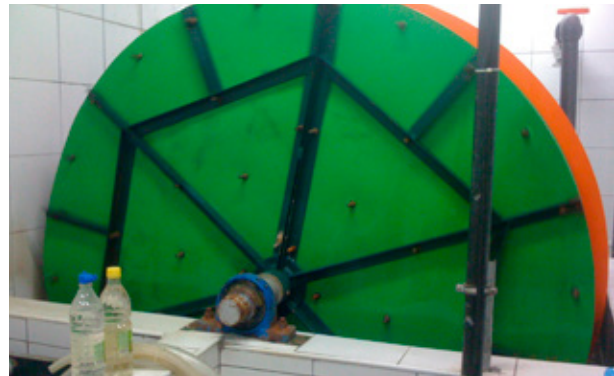

Rotor can be placed in concrete pool built by the client. This is a common method when there are several RBC biodisk units to be installed. Such method saves footprint and money.

PlanetDISK® RBC Biodisk units can be placed in buildings half buried in ground. Such method will help save heat to protect Waste water from freezing in cold climate.

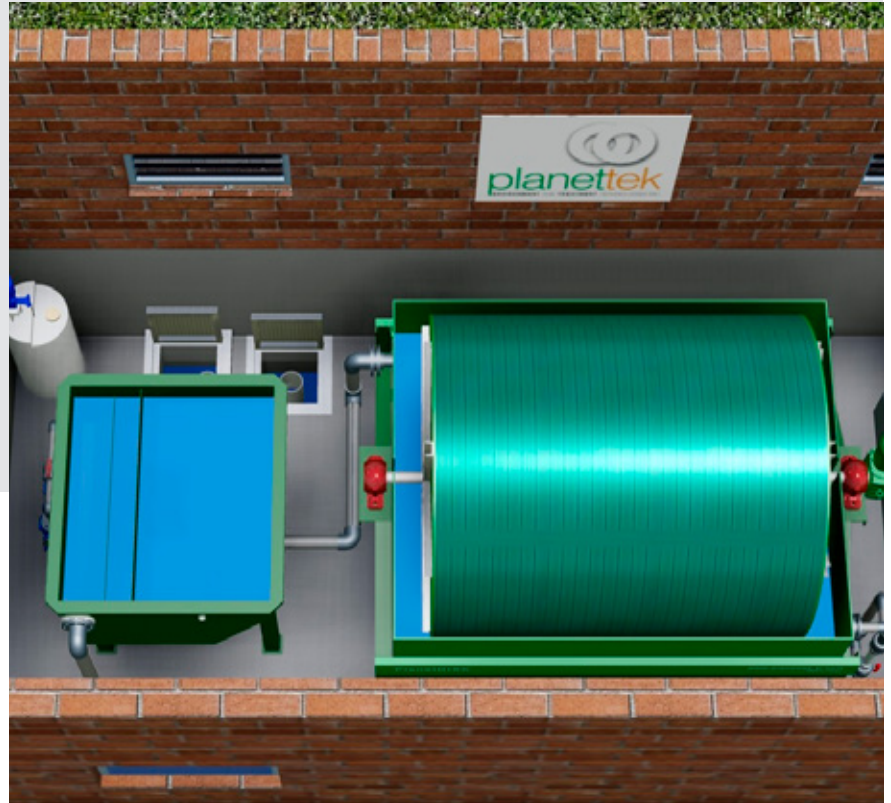
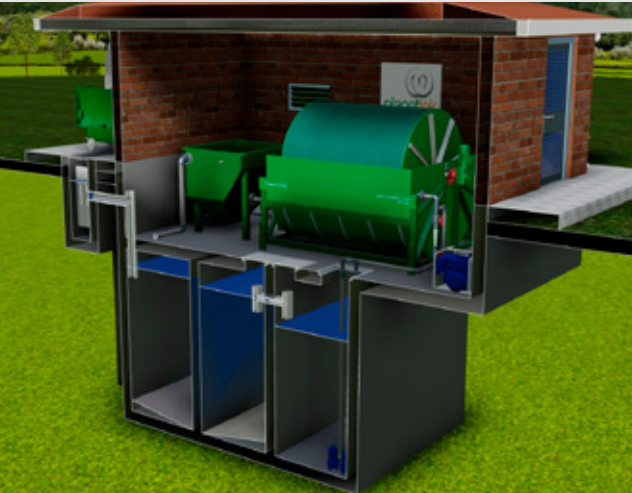

PlanetDISK® Units can be placed under the ground if there is adequate ventilation.

Upto 150 m³/day capacities, PE tanks can be used for sedimentation and equalization tanks, replacing concrete tanks.



Secret to success is “Right Decisions”
 The secret to right decisions is “Experience”

After many years of hard work, R&D and lots of experience at the field, **PlanetDISK®** has become one of the best known robust RBC brands with the most consistently satisfying results.

In 2015, VEOLIA, has chosen **PlanetDISK®** for their 1500m³/day project. We are proud.



PlanetDISK® RBC units are ready to be shipped to the WORLD!
 We can deliver upto 6 units per week and even push the limits when there is time stress.

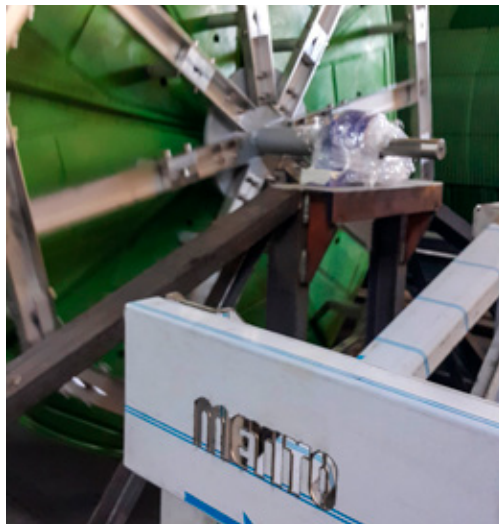

PlanetDISK® is preferred by the Chilean Environment and Construction company Capital Water for the luxurious housing project in Ghana! PlanetDISK® is a well known RBC Equipment brand in the international market.

Qatar's Metito Company prefers PlanetDISK® RBC Equipment in most projects.

When it comes to sustainable and reliable solutions in waste water treatment, PlanetDISK® is there, where the revolution starts.





PlanetDISK® now serves in 4 continents.

**MADE IN
TÜRKİYE**

Our Pride List



أرامكو السعودية
Saudi Aramco



HEAL GROUP
AUSTRALIA



ENKA



TEKFEN CONSTRUCTION
 Tekfen Construction and Installation Co., Inc.
 Taksim Tower, Akmerkez Center, No: 100 4. Kat, Kat: 1004, İstanbul, Turkey
 Tel: +90 212 347 20 20 / 20 20 17 / 20 20 22 22 / 20 20 22 22
 www.tekfen.com.tr / www.tekfenusa.com

Istanbul, November 2nd, 2011
 Ref: 2011/1909



To whom it may concern,

We have ordered PlanetDISK® RBC systems for our World Bank funded project of BTC – Baku-Tiflis-Ceyhan pipeline. The PlanetDISK® waste water treatment system has been in use at 2 of our stations for the last 14 months and at another station for over 2 yrs. We have observed that with exception of some start rods of 12 mm. diameter failing at 2 stations, the system has been working without any failure at all. Start rods being the only problem, we have also observed that CTG PlanetTEK always gave prompt and professional technical service beyond our expectation.

Although the targeted effluent criteria for BOD ≤ 25 mg/L., the actual effluent has been around 5-15 mg/L.

RBC is preferred by our client BP for its easy maintenance, reliable and consistent process results. RBC is also known for its less energy usage. PlanetDISK® is a successful example of RBC technology. BTC pump stations located at 3000 m altitude has very harsh climate conditions and yet PlanetDISK® system has been working and yielding consistently good result.

Should we need any other compact waste water treatment units, we would prefer RBC technology and PlanetDISK®.

We thank CTG PlanetTEK for an excellent system and technical service.



Our Pride List

Global Clients

VEOLIA, Kingdom of Saudi Arabia, Military Base
 HEAL Group of Australia – Refugee Camp
 Metito Doha, Qatar
 Aramco - TEKFEN - ALFEN Construction site - K. of Saudi Arabia
 ECETAŞ Construction, Batum Villages, Georgia
 Northern Cyprus Turkish Republic, Military station
 LIPTON Social Responsibility Project- Rize Villages
 Ankara Rotary Club - Vezirköprü village, Samsun
 Maslak İstanbul Rotary Club Village Project, İğneada
 BP/Tekfen - Bakü/Ceyhan Boru Hattı BTC pipeline
 SNC LAVALIN CANADA Gold Mine Company - Erzincan
 ENKA Construction - Algeria Project
 Bahreyn Oil Drill Company - Prekons
 DDFC Project Pakistan - Factory STP
 Eau Debit of Morocco

Local Clients

Mardin Province, Türkiye, Sürgücü Village (4500 pe/day)
 MYC Construction, Mila's Daphne Hotel Bodrum, Türkiye
 Houses - Ankara Water and Sewage Authority 4 villages
 European Union Funded Solar Energy House - Diyarbakır
 ANDICEN (Sabancı) Villaları - Vanikoy, İstanbul
 Almat Rönesans Villaları, Zekeriyaköy, İstanbul
 Mytown Villaları - Zekeriyaköy - İstanbul
 Bayır Villaları - Zekeriyaköy - İstanbul
 Mavi Yıldız Villaları- Zekeriyaköy - İstanbul
 Miika Construction - Sarıyer - İstanbul
 Parkone - ÇİLLER Villaları, Zekeriyaköy, İstanbul
 İstanbul Municipality - Dragos Social Facilities
 BEZEK Rubber Tyres - Adapazarı, Türkiye
 Parkville Villaları - Formula 1 - İstanbul
 Berggruen Villaları - Gümüşlük - Bodrum - Türkiye
 İğneada, Kırklareli Municipality - 5000 pe capacity
 EYFEL construction, KIDS Town – Riva, İstanbul
 Edirne Province. Türkiye, Villages
 Amasya Province 3 villages
 Balıkesir Province BASKİ – 2 small towns of 3500 people
 TOKİ Project in Sereflikochisar Town
 Kırşehir 4 villages
 Canakkale - Gallipoli Villages



International Rotary Clubs has also preferred PlanetDISK® systems for social responsibility projects in Turkey. Rotary Clubs have sponsored waste water treatment plant projects in villages.



Total of 3 pumping stations along the Baku-Tbilisi-Ceyhan pipeline are awarded to PlanetTEK. The end user BP prefers RBC for easy maintenance and energy efficiency.



Kid's Town Residence in İstanbul. Smell and noise issues were very critical at this residence and that is the main reason PlanetDISK® RBC System was preferred.

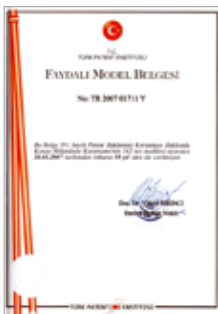

PlanetDISK® vs Conventional Systems

	PlanetDISK®		Conventional Activated Sludge
Method	Rotating Biological Contactor - RBC	✓	Activated Sludge (AS)
Noise level	Very low <60 db	✓	Annoying, humming>100 db
Odor	Negligible	✓	Usually at disturbing levels
Corrosion	All metal parts in contact with wastewater are stainless or galvanized steel. HDPP, PE and GRP will endure corrosion for over 50 years.	✓	Excessive rust and corrosion usually within 3-4 years Life expectancy is <10 years.
Maintenance	Does not require constant attention or sophisticated instrumentation for any kind of measurements. The process results is not dependent the human factor. No special care is needed other than lubricating bearings monthly, washing lamella seperator once a week for 15 - 20 minutes and maintaining the coarse and fine screens.	✓	The operator must constantly be aware of conditions that could lead to poorly settling sludge or inadequate BOD removal. This requires continual monitoring of the wastewater. The process results depends on human skills.
Power and operating cost	Less than \$0.1 per person per month, minimum power consumption among all waste water tratment methods. Minimum spare parts needed due to a few moving parts.		Due to powerful blower, 8 -9 times more power consumption. High speed rotating blowers require frequent maintenance.
Space requirement	Almost 50% less footprint than AS	✓	Requires bigger space.
Sludge amount	Fixed film systems generate fewer and more concentrated solids than AS. This results in smaller clarifiers and reduces the size of solids handling systems. Almost 50% less than activated sludge requirement.	✓ ✓	Sludge produced is usually 50% more than the fixed film systems. Technical literature regarding AS is filled with advice on how to avoid filamentous growth, foaming, dispersed growth, and other situations that lead to poor liquid/ solids separation and poor effluent quality.



Refugee Center for Syrians in Türkiye.
Built by EU funds.

PlanetDISK® at use:

Domestic waste water, housing sites, hotels, villages, schools, factories, refugee camps, shopping centers and plazas, construction and mining sites labor camps.

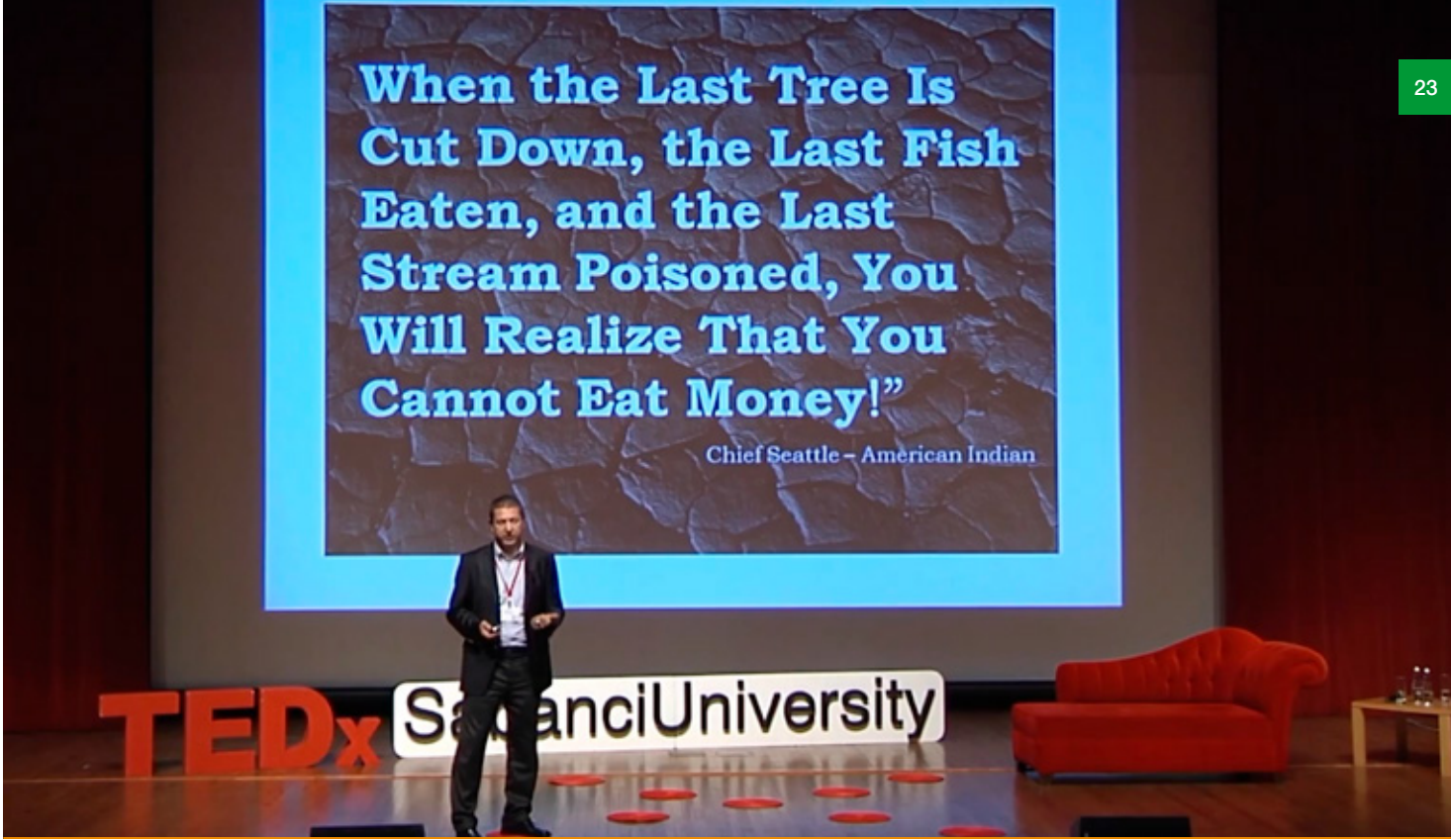

I asked myself;

“What am I going to tell my grandchildren when they ask me what I have done to leave a better Planet for them?”

I had to do something. I established PlanetTEK.

One PlanetDISK® at a time, we are determined to make a change for a sustainable, better Planet by treating waste water and not allowing it to pollute the clean water resources. Better yet, PlanetDISK® allows us to reuse the waste water.

Hürriyet Necdet Aydoğan – Founder of PlanetTEK

Hürriyet Necdet Aydoğan shared the inspiring story of PlanetTEK at **TEDx**.

You can find the speech “The World Needs ‘HEROES’ ” by searching the keywords “TEDx Aydogan” at YouTube.

You may also scan the QR code to reach the **YouTube** link.

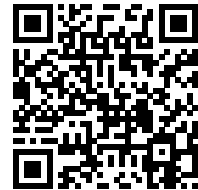

Endeavor is an international NGO, finding and supporting high impact entrepreneurs who have excelled in ethical means and are role models in society. PlanetTEK was among the finalists of 2008.



Hürriyet Newspaper 4 May 2008 PlanetTEK, Endeavor Finalist.



When we protect our water resources we actually protect all our beloved ones. Our children, animals, homes, country...

Whatever we love, can only exist if there is clean water.



Please scan QR code to reach PDF version of this catalog and **YouTube** link of a PlanetDISK® STP in Istanbul.

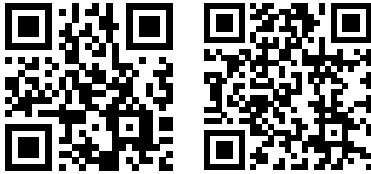

Headquarter:

Fatih Sultan Mehmet Cd.
Onarımlı Sk. Altay Han 9/2
34810 Kavacak / Beykoz
İSTANBUL - TÜRKİYE
Tel : +90 216 425 6051 pbx
Fax : +90 216 425 6053

info@planettek-tr.com
www.planettek-tr.com
www.sutemiz.com
www.planettek-usa.com



Offices:

4354 Tuller Road. Dublin,
Ohio 43017 USA
Tel : +1 (440) 781-3609

Basım Tarihi: 10 Mayıs 2018
Baskı: Ses Reklamcılık Paz.Tur. San. ve Tic. Ltd. Şti.



www.kosgeb.gov.tr